

Instruction Sheet - Endura Mobile Cabinet Tables

Models LE27C

Customer Service Department

Luxor

2245 Delany Road

Waukegan, IL 60087

Ph: 847/244-1800 • 800/323-4656

Fax: 847/244-1818 • 800/327-1698



LE27C

PARTS LIST

Models LE27C

- 1 - Top shelf w/handle
- 1 - Bottom shelf w/caster sockets
- 4 - Legs
- 2 - Cabinet side panels
- 1 - Back Panel
- 1 - Door in frame
- 1 - Power cord
- 4 - Casters 2 with brake
- 8 - 1 3/4" machine screws

- 1 - Grommet Cap
- 1 - Cord guide cover
- 2 - Grommet rings
- 1 - Rubber Band
- 4 - Small "U" brackets
- 1 - Large "U" bracket
- 1 - Cord wrap bracket
- 2 - Stove bolts

Tools Required:

Rubber mallet

If you did not get an electric assembly with your cart start by closing the electric plug housing in the handle of the top shelf as illustrated below.

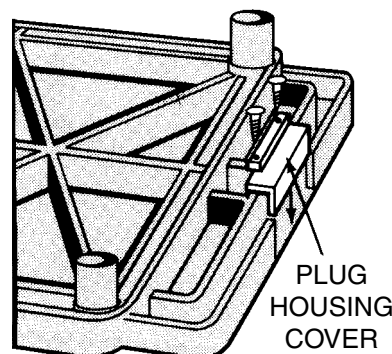

NOTE: Model LE-27C had double doors.

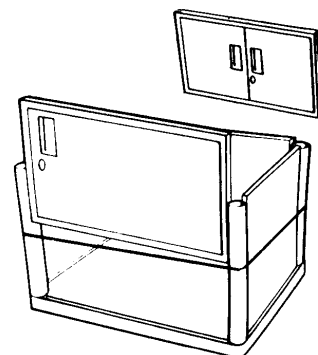

5 Install door panel same as back panel with door handle at top. Be sure door opens outward and door frame is also placed between legs and nested flush on the shelf floor.

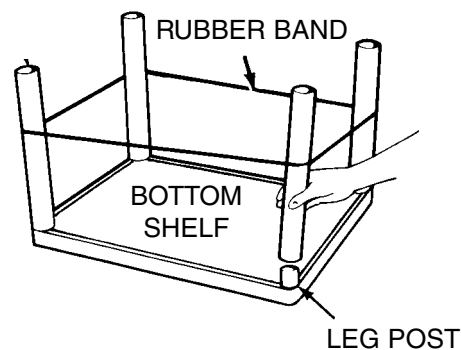

1 With bottom shelf facing up push all four legs onto leg posts. Using rubber mallet hammer legs firmly into position. Legs must be seated (flush) against the shelf surface. Place rubber band around legs to aid in the assembly of cabinet side panels and doors.

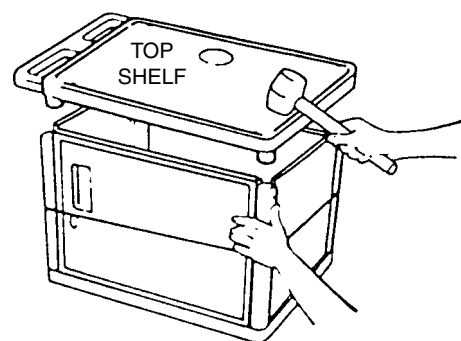

6 Begin seating of top shelf by holding door panel, leg and side panel as illustrated. Gently tap corner posts into legs until all posts are partially inserted into legs. Repeat hammering action more firmly going around to each corner, being certain that each panel nests inside the lip of the top shelf. Repeat this action until top shelf is fully nested.

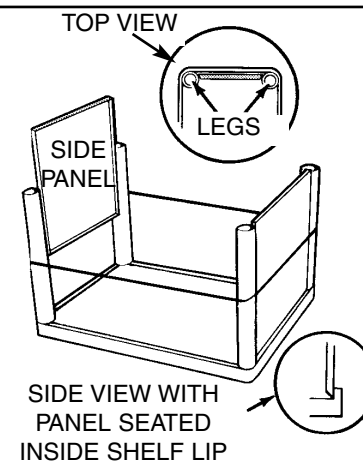

2 Install the side panels first. Slide panels down between legs until they are nested inside the shelf lip and flush against the shelf surface. Rubber band will hold legs and side panels in place while installing back panel and front door.

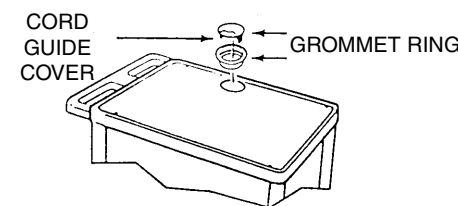

7 Install grommet ring and grommet cap into top shelf. For tables with electric assembly, snap off cord guide cover from grommet cap to allow equipment plug entry. Insert grommet cap into grommet ring.

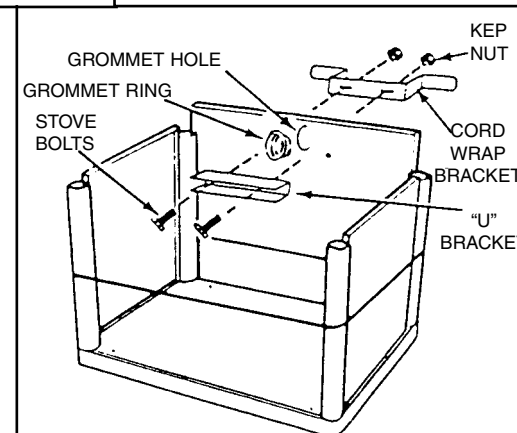

3 Install the back panel in the same manner as side panels. Install grommet ring into grommet hole. Insert two stove bolts as illustrated through "U" bracket into back panel and through slots in cord wrap bracket. Align the cord wrap bracket onto stove bolts from the outside of back panel, and secure with two keep nuts.

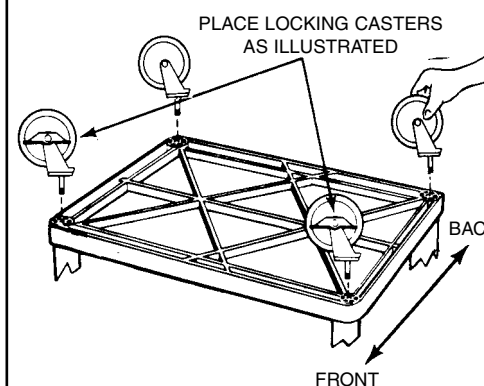

8 Push the four casters firmly into the holes in each corner of the bottom shelf. **Important:** casters must be fully seated. Tap firmly with rubber mallet to properly seat casters. Turn your Endura Table right side up.

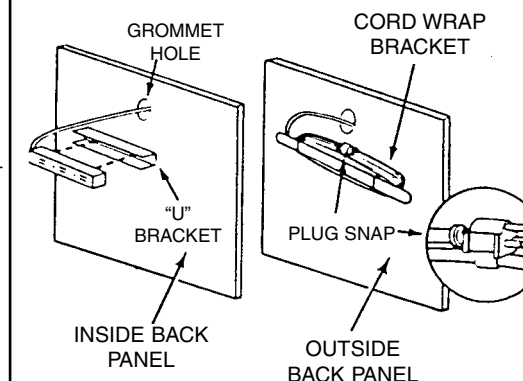

4 Press 3-outlet power cord into "U" bracket and feed remaining cord through grommet hole and wrap remaining cord around cord wrap bracket. For safety and neat appearance, secure cord plug to cord with plug snap.

Instructions For - Electrical Assembly

Cable-Track™ Management System and Cord Wrap

Your Endura mobile equipment table incorporates the Cable-Track™ cord management system. This exclusive feature manages electrical cords, keeping them safely out of the way. This system includes a 3-outlet, 15 foot surge suppressing electric assembly (U.L. and C.S.A.

listed) which is built into the safety handle. Please review these instructions carefully to maximize the added safety provided by Luxor's Cable-Track™ cord management system.

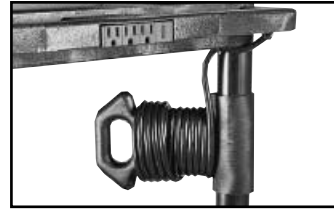

Parts List

1 - Surge protected power cord	1 - Power cord retainer clip
1 - Cord wrap	2 - "E"-clips
4 - Cord management ties	4 - Sheet metal screws

ILLUSTRATION A

Important

1. The electrical unit should be assembled first.

Cord wrap must be installed on leg before assembly of complete unit.
*See below (See Illus. B).

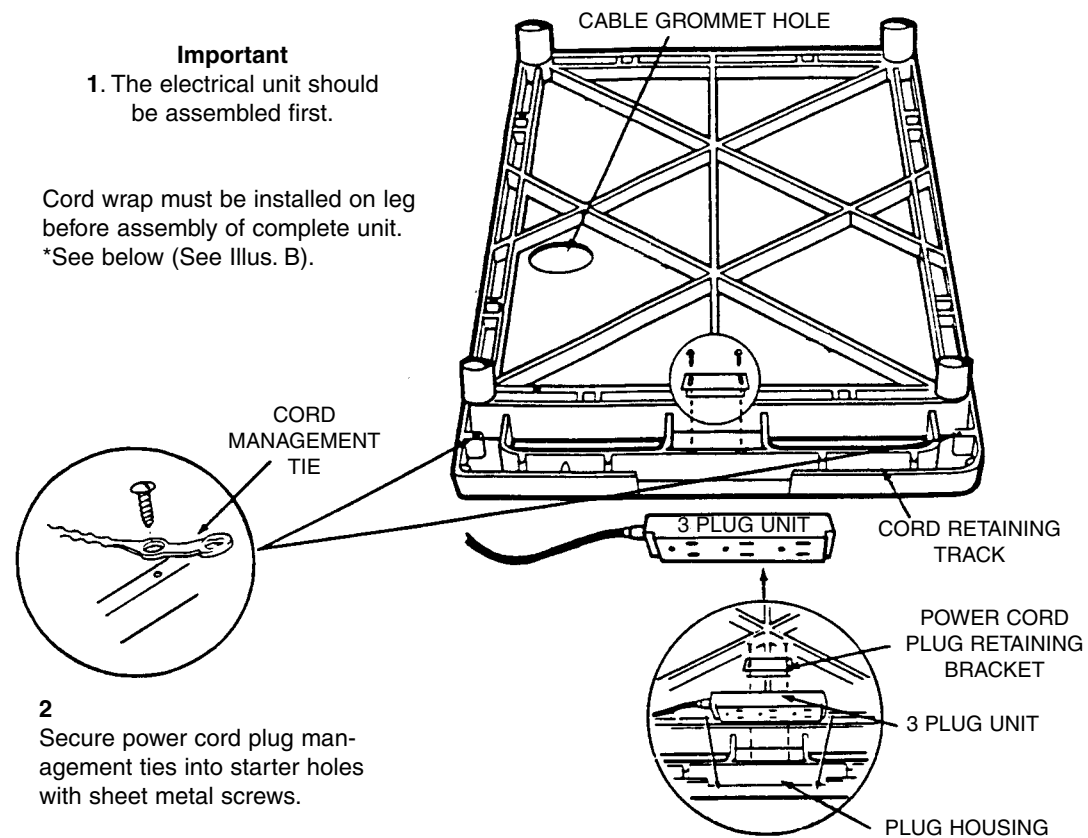

3. Firmly seat electric assembly 3 plug unit into handle plug housing as illustrated. Secure with power cord plug retaining bracket.

ILLUSTRATION B

Install correct size leg on top shelf then slide cord wrap down over leg into position.

4. Thread power cord through cord retaining track, secure with cord management ties by wrapping tie around cord and fastening. Cut off any unnecessary extra length of tie. Wrap remaining cord around the cord wrap bracket. For safety and new appearance, secure cord plug to cord by utilizing plug snap.

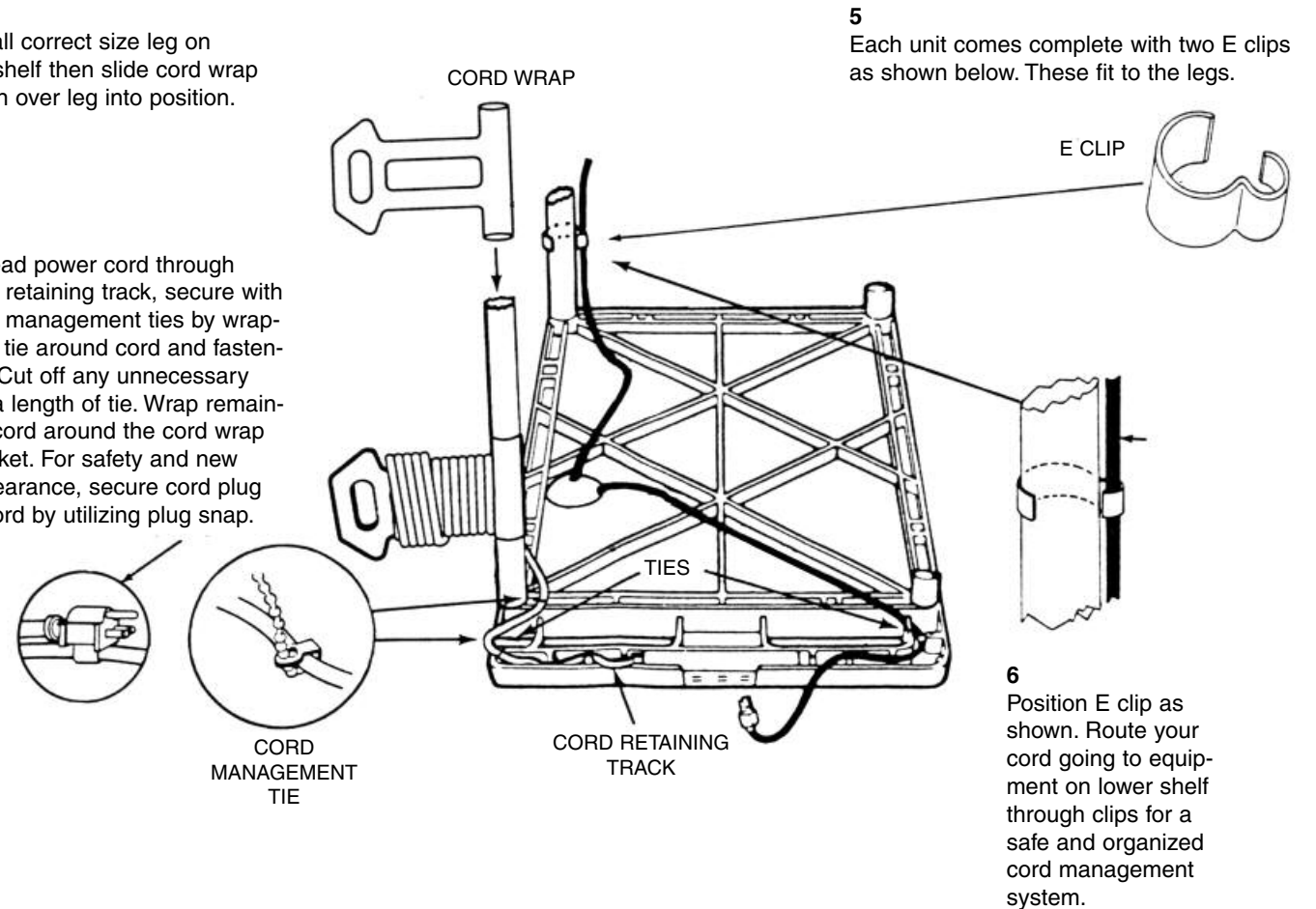

5. Each unit comes complete with two E clips as shown below. These fit to the legs.

6. Position E clip as shown. Route your cord going to equipment on lower shelf through clips for a safe and organized cord management system.